

8.01 发动机排气制动及操纵装置/Engine Exhaust Brake System

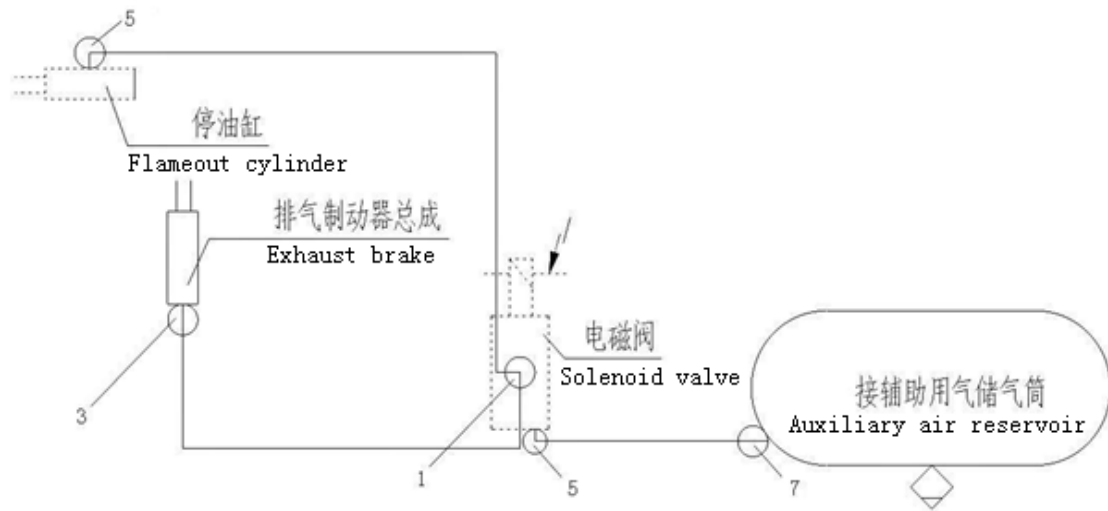

8.01 发动机排气制动及操纵装置/Engine Exhaust Brake System

序号 No.	零部件图号 Part No.	名称	Part Name	数量 Qty	备注 Remark
1	WG9000361308	L型三通接头体NG6/NW4	"L" connector NG6/NW4	2	
3	WG9000361107	直通接头体NG6/NW4	Connector NG6/NW4	2	
5	WG9000361207	直角接头体NG6/NW4	Connector NG6/NW4	1	
7	WG9000361103	直通接头体NG12/NW4	Connector NG12/NW4	1	
	WG9000361001	弹性元件NG6	Elastic part NG6	3	
	WG9000361002	卡簧NG6	Snap spring NG6	3	
	WG9000361003	螺母座NG6	Nut seat NG6	3	
	190003179782	聚酰胺管 (Φ6*1)	Plastic pipe (Φ6*1)	4m	
	1880 360083	支承板	Plate	1	
	Q150B1035	六角头螺栓	Screw	1	
	Q40110	平垫圈	Washer	1	
	Q40310	弹簧垫圈	Spring washer	1	
	Q340B10	六角螺母	Nut	1	
	WG9100360134	隔环	Spacer ring	1	
	190003171390	塑料紧固带	Fastener	1	

8.02 辅助用气分配模块/Air distributor block



8.06 双音气喇叭操纵装置（金属保险杠）/Horn Air System

序号 No.	零部件图号 Part No.	名称	Part Name	数量 Qty	备注 Remark
2	WG9000270002	双音气喇叭无支架	Air horn	1	
4	Q150B0665	六角头螺栓	Screw	2	
5	Q40106	平垫圈	Washer	4	
6	Q40306	弹簧垫圈	Spring washer	4	
7	Q340B06	I型六角螺母	Nut	4	
8	WG9000361109	直通接头体NG8/NW4	Connector NG8/NW4	1	
10	WG9000361107	直通接头体NG6/NW4	Connector NG6/NW4	3	
12	WG9000361001	弹性元件NG6	Elastic part NG6	2	
14	WG9000361002	卡簧NG6	Snap spring NG6	2	
16	WG9000361003	螺母座NG6	Nut seat NG6	2	
18	190003179782	聚酰胺管（Φ6*1）	Plastic pipe（Φ6*1）	8m	
19	WG9718710003	气喇叭电磁阀	Solenoid valve	1	
21	Q150B0816	六角头螺栓	Screw	1	
22	Q41208	外锯齿锁紧垫圈	Washer	1	
25	WG9725270017	双音气喇叭支架	Bracket	1	
27	Q150B0625	六角头螺栓	Screw	2	

8.07 辅助用气储气筒装置/Air Supply Device

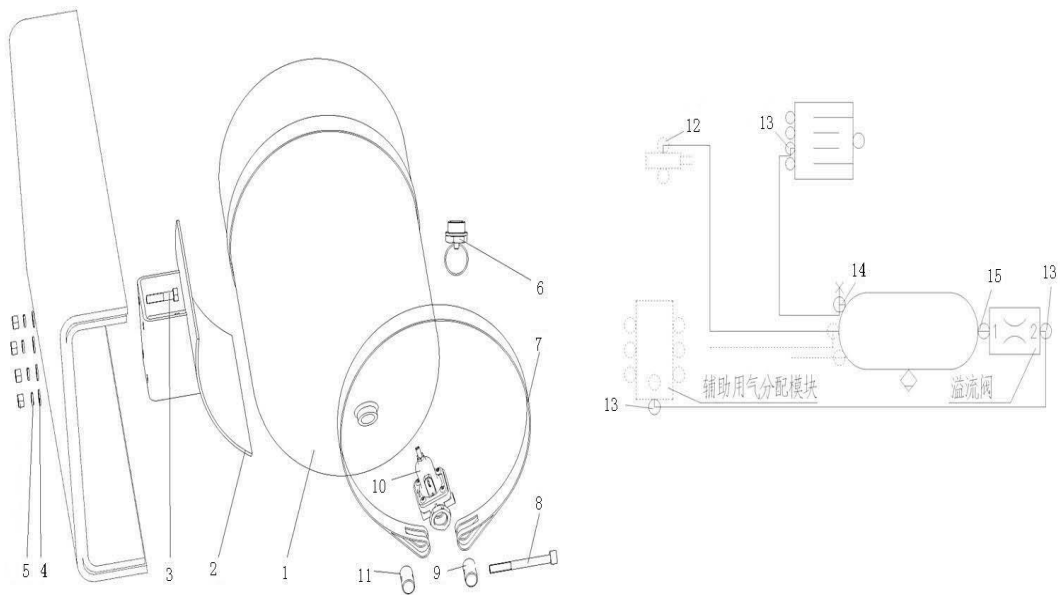

8.07 辅助用气储气筒装置/Air Supply Device

序号 No.	零部件图号 Part No.	名称	Part Name	数量 Qty	备注 Remark
1	WG9000360716	储气筒总成Φ275/20L	Air reservoir (20L)	1	
2	WG9719360020	储气筒托架总成	Bracket	1	From 20110425
3	Q150B1030	六角头螺栓	Screw	4	
4	Q40110	平垫圈	Washer	4	
5	Q40310	弹簧垫圈	Spring washer	4	
6	WG9000361402	放水阀	Draining valve	1	
7	WG9719360024	紧固带总成	Tension strap	2	
8	Q218B0880	内六角圆柱头螺钉	Screw	2	
9	WG700 550013	张紧销	Tension bolt	2	
10	WG9000360519	溢流阀0.6MPa无回流	Over-flow valve	1	
11	WG09 190017	拉紧销	Tension bolt	2	
12	WG9000361201	直角接头体NG8/NW6	Connector NG8/NW6	1	
13	WG9000361204	直角接头体NG12/NW9	Connector NG12/NW9	3	
14	WG9000361406	T型接头体NW9/NG12/TEST	"T" Connector NW9/NG12/TEST	1	
15	190003559385	隔壁直通接头体2-M22×	Connector 2-M22×1.5	1	
16	WG9000361004	弹性元件NG8	Elastic part NG8	1	
17	WG9000361005	卡簧NG8	Snap spring NG8	1	
18	WG9000361006	螺母座NG8	Nut seat NG8	1	
19	WG9000361007	弹性元件NG12	Elastic part NG12	5	
20	WG9000361008	卡簧NG12	Snap spring NG12	5	

8.07 辅助用气储气筒装置/Air Supply Device

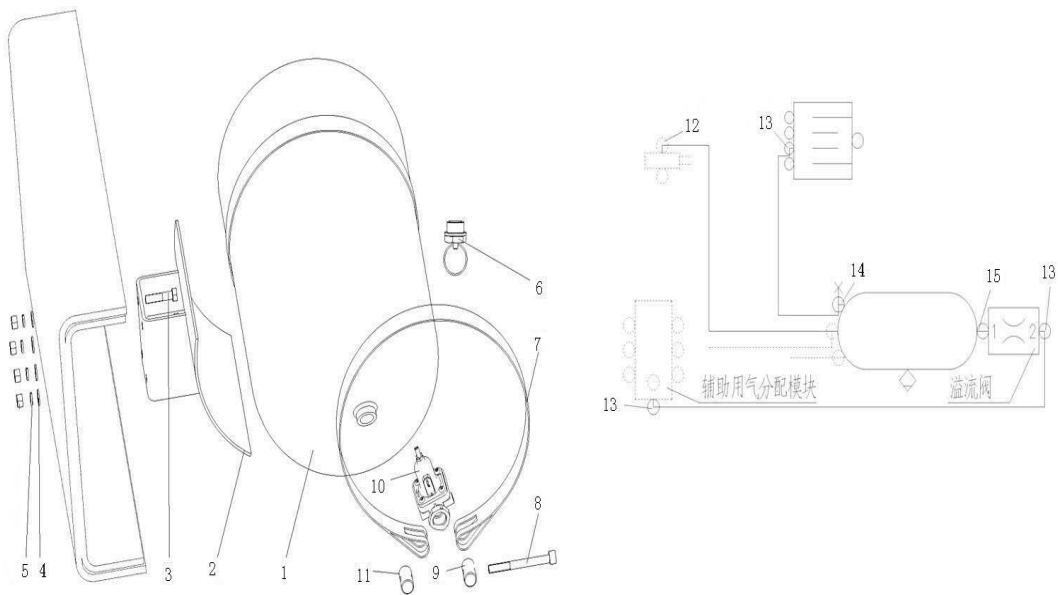

12	Q340B08	1型六角螺母	Nut	1	
13	AZ9718360010	角形支架	Angle bracket	1	
14	Q340B08	1型六角螺母	Nut	2	
15	Q150B0635	六角头螺栓	Screw	1	
16	1185 770036	紧固夹子	Clip	1	
17	Q40108	平垫圈	Washer	2	
18	AZ9719360006	支架	Bracket	1	
19	1381F 140090	护套	Protecting sleeve	1	
20	Q150B0620	六角头螺栓	Screw	1	

8.12 制动系统供气装置/Air Supply Device

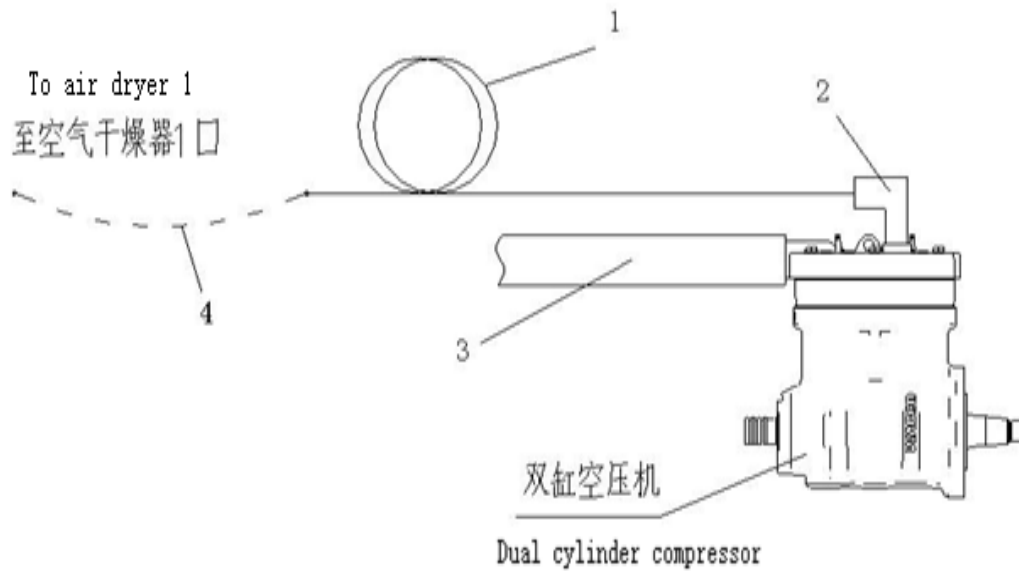

8.12 制动系统供气装置/Air Supply Device

序号 No.	零部件图号 Part No.	名称	Part Name	数量 Qty	备注 Remark
21	Q40308	弹簧垫圈	Spring washer	2	
22	190003989340	软管卡箍	Hose clip	2	
23	190003559562	卡套	Cutting sleeve	2	
24	Q40106	平垫圈	Washer	2	
25	Q150B0845	六角头螺栓	Screw	1	
26	Q40306	弹簧垫圈	Spring washer	2	
27	WG80 360199	夹子	Clip	2	
28	Q150B0830	六角头螺栓	Screw	1	
29	AZ9719360007	支架	Bracket	1	
30	Q340B06	1型六角螺母	Nut	2	
31	190003559515	管接头用螺母	Nut	2	
32	190003098031	密封垫圈	Sealing washer	1	
33	WG9125360209	螺旋管固定支架	Bracket	1	
34	WG9000365401	单管夹(Φ15)	Clip(Φ15)	4	
35	Q40206	大垫圈	Washer	4	

36	WG9718360010	角形支架	Angle bracket	1	
37	Q150B0845	六角头螺栓	Screw	1	
38	199012360441	角形支架	Angle bracket	2	
39	Q150B0830	六角头螺栓	Screw	2	
40	WG9000365403	双管夹 (φ15)	Clip (φ15)	1	
41	WG9000365404	双管夹 (φ15)	Clip (φ15)	1	

8.13 驾驶室制动装置/Brake Device In Cab

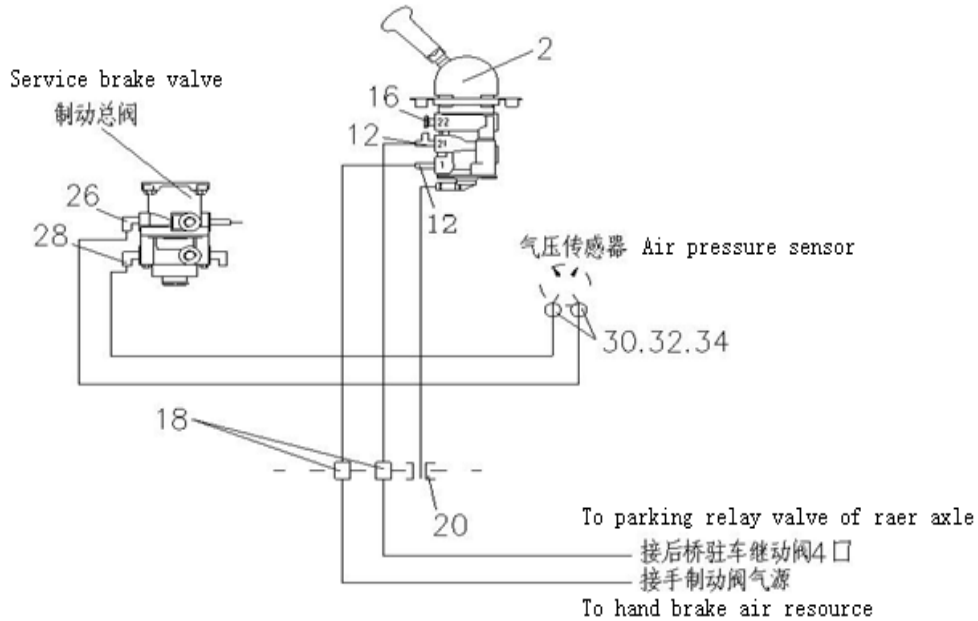

8.13 驾驶室制动装置/Brake Device In Cab

序号 No.	零部件图号 Part No.	名称	Part Name	数量 Qty	备注 Remark
2	WG9000360522	手制动阀	Parking brake valve	1	
4	Q150B0616	六角头螺栓	Screw	2	
5	Q40306	弹簧垫圈	Spring washer	2	
6	WG9000361004	弹性元件NG8	Elastic part NG8	2	
8	WG9000361005	卡簧NG8	Clip NG8	2	
10	WG9000361006	螺母座NG8	Nut seat NG8	2	
12	WG9000361307	L型三通接头体NG8	"L" connector NG8	2	
16	WG9000361011	堵塞NG8-M16×1.5	Plug NG8-M16×1.5	1	
18	WG9000361403	组合踏板支架过板接头	Connector	2	
20	WG9719360018	橡胶护套	Sleeve	1	
22	WG9719360019	堵塞	Plug	5	
24	WG9725360036	方型堵塞	Plug	1	
26	WG9000361207	直角接头体NG6/NW4	Connector NG6/NW4	1	
28	WG9000361107	直通接头体NG6/NW4	Connector NG6/NW4	3	
30	WG9000361108	直通隔壁接头体NG6	Connector NG6	2	
32	WG9000361013	六角薄螺母M16X1.5	Nut M16X1.5	2	
34	WG9000361032	O型圈13X2	O-ring 13X2	2	

8.15 双桥制动装置/Double Drive Axle Brake Device

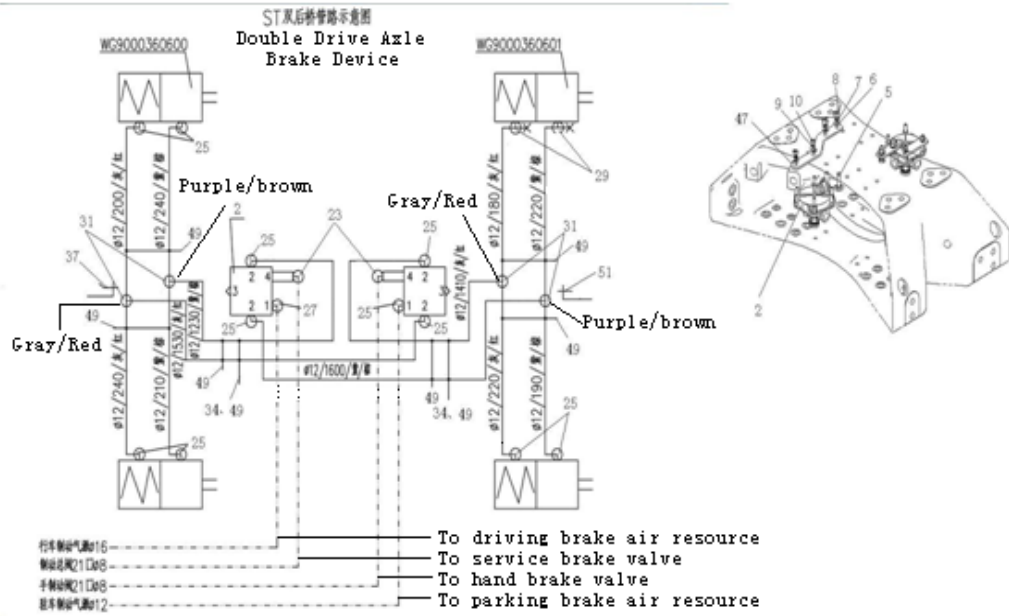

8.15 双桥制动装置/Double Drive Axle Brake Device

序号 No.	零部件图号 Part No.	名称	Part Name	数量 Qty	备注 Remark
2	WG9000360524	继动阀	Relay valve	2	
5	Q150B1035	六角头螺栓	Screw	4	
6	Q40110	平垫圈	Washer	4	
7	Q40310	弹簧垫圈	Spring washer	4	
8	Q340B10	六角螺母	Nut	4	
9	Q40308	弹簧垫圈	Spring washer	4	
10	Q340B08	1型六角螺母	Nut	4	
11	WG9000361004	弹性元件NG8	Elastic part NG8	2	
13	WG9000361005	卡簧NG8	Snap ring NG8	2	
15	WG9000361006	螺母座NG8	Nut seat NG8	2	
17	WG9000361007	弹性元件NG12	Elastic part NG12	14	
19	WG9000361008	卡簧NG12	Snap ring NG12	14	
21	WG9000361009	螺母座NG12	Nut seat NG12	14	
23	WG9000361201	直角接头体NG8/NW6	Connector NG8/NW6	2	
25	WG9000361204	直角接头体NG12/NW9	Connector NG12/NW9	11	
27	WG9000361203	直角接头体NG12/NW12	Connector NG12/NW12	1	
29	WG9000361406	T型接头体NW9/NG12/TES	"T" Connector NW9/NG12	2	
31	WG9000361310	T型三通接头体3-NW9	"T" Connector 3-NW9	4	
33	190003179785	聚酰胺管(Φ12*1.5)	Plastic pipe	9m	
34	WG9725360088	塑料紧固带总成	Fastener	4	

8.15 双桥制动装置/Double Drive Axle Brake Device

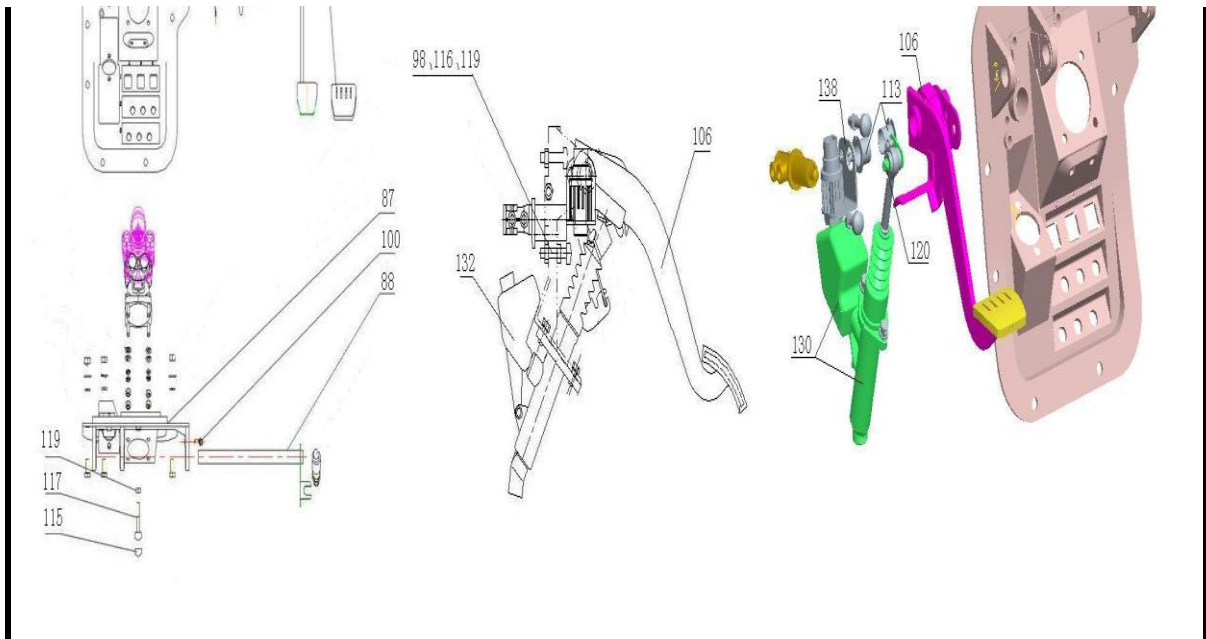

8.16 HOWO组合踏板操纵装置(新开关/共轨)/Combined Pedal Control Device

序号 No.	零部件图号 Part No.	名称	Part Name	数量 Qty	备注 Remark
2	AZ9725361021	HOWO组合踏板操纵总成	Pedal ass.	1	
75	WG9000361007	弹性元件NG12	Elastic part NG12	4	
77	WG9000361008	卡簧NG12	Snap spring NG12	4	
79	WG9000361009	螺母座NG12	Nut seat NG12	4	
86	AZ9725360020	组合支架	Bracket	1	
88	AZ9719360051	芯轴总成	Shaft ass.	1	
89	AZ9719360055	制动踏板总成	Service brake pedal	1	
90	AZ9719360060	自润滑衬套	Sleeve	2	
91	AZ9123230226	踏板橡胶罩	Rubber cover	1	
92	AZ9719360063	挺杆	Push rod	1	
93	Q173B0845	六角头螺杆带孔螺栓	Screw	1	
94	Q5002016	开口销	Split pin	1	
95	Q341B08	1型六角螺母-细牙	Nut	1	
96	AZ9719360062	销轴	Shaft	1	
97	Q150B0845	六角头螺栓	Screw	1	
98	AZ9123360067	堵头	Plug	1	
99	Q340B08	1型六角螺母	Nut	1	
100	Q1840616	六角法兰面螺栓	Screw	1	
101	WG9000360520	制动总阀	Service Brake Valve	1	
102	Q33208	2型全金属六角锁紧螺母	Nut	4	

8.16 HOWO组合踏板操纵装置(新开关/共轨)/Combined Pedal Control Device

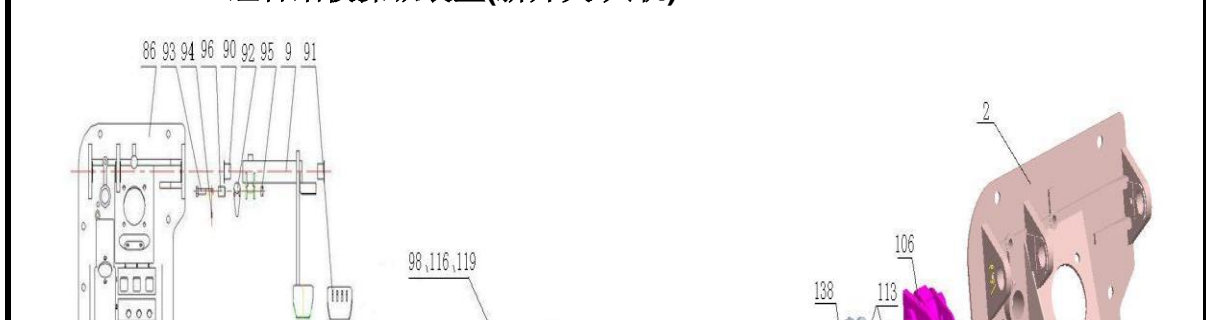

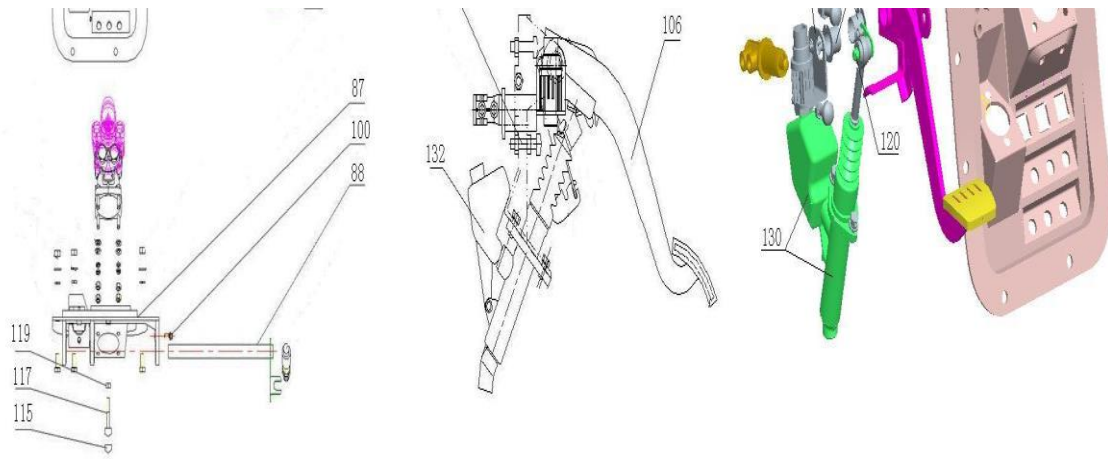

8.16 HOWO组合踏板操纵装置(新开关/共轨)/Combined Pedal Control Device

序号 No.	零部件图号 Part No.	名称	Part Name	数量 Qty	备注 Remark
103	Q40308	弹簧垫圈	Spring washer	4	
106	AZ9719230225	离合器踏板总成	Clutch pedal ass.	1	
113	AZ9719360060	自润滑衬套	Sleeve	2	
114	AZ9123230226	踏板橡胶罩	Rubber cover	1	
115	AZ9123360067	堵头	Plug	2	
116	Q150B0830	六角头螺栓	Screw	1	
117	Q150B0845	六角头螺栓	Screw	1	
118	Q40308	弹簧垫圈	Spring washer	2	
119	Q340B08	1型六角螺母	Nut	2	
120	AZ9719230228	销轴总成	Shaft ass.	1	
123	Q150B0616	六角头螺栓	Screw	1	
124	Q40106	平垫圈	Washer	1	
125	Q40306	弹簧垫圈	Spring washer	1	
126	Q340B06	I型六角螺母	Nut	1	
127	AZ9719230222	离合器总泵推杆	Rod ass.	1	
128	AZ9123230053	无内圈滚针轴承	Needle bearing	1	
129	AZ9719230229	垫圈	Washer	2	
130	WG9719230023	离合器总泵及储油罐总成	Clutch master cylinder and oil tank	1	
130,1	WG9719230014	离合器储油罐	Oil tank	1	
130,2	WG9719230015	离合器总泵	Clutch master cylinder	1	

8.16 HOWO组合踏板操纵装置(新开关/共轨)/Combined Pedal Control Device

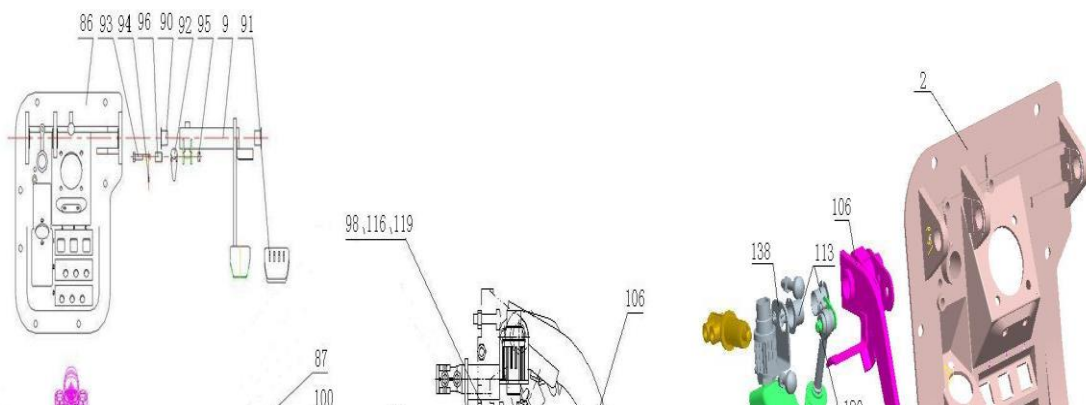

8.17 牵引底盘制动装置/Chassis Brake Device

序号 No.	零部件图号 Part No.	名称	Part Name	数量 Qty	备注 Remark
1	WG9000360521	空气干燥器	Air dryer	1	
4	Q151C1230	六角头螺栓(细牙)	Screw	3	
5	Q40112	平垫圈	Washer	3	
6	Q40312	弹簧垫圈	Spring washer	3	
7	Q150B1025	六角头螺栓	Screw	3	
8	Q40110	平垫圈	Washer	3	
9	Q40310	弹簧垫圈	Spring washer	3	
10	Q340B10	六角螺母	Nut	3	
11	WG9000360523	四回路保护阀	4-circuit protecting valve	1	
13	AZ9719360013	四回路保护阀支架	Bracket	1	
14	Q150B1020	六角头螺栓	Screw	2	
15	Q40110	平垫圈	Washer	2	
16	Q40310	弹簧垫圈	Spring washer	2	
17	Q340B10	六角螺母	Nut	2	
18	Q150B0818	六角头螺栓	Screw	2	
19	Q40308	弹簧垫圈	Spring washer	2	
20	WG9000360712	储气筒总成双腔Φ246/20+5L	Air reservoir (20L+5L)	1	
25	WG93 250096	隔套	Spacer sleeve	4	
27	Q150B1065	六角头螺栓	Screw	4	
28	WG9731360005	紧固带总成	Tension strap	2	

8.17 牵引底盘制动装置/Chassis Brake Device

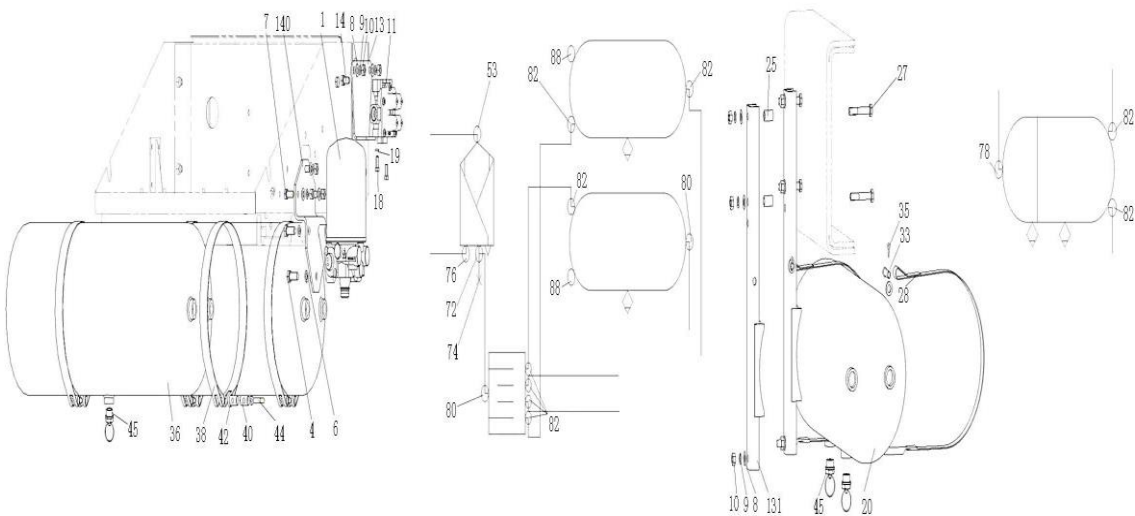

8.17 牵引底盘制动装置/Chassis Brake Device

序号 No.	零部件图号 Part No.	名称	Part Name	数量 Qty	备注 Remark
30	Q40110	平垫圈	Washer	6	
31	Q40310	弹簧垫圈	Spring washer	6	
32	Q340B10	六角螺母	Nut	6	
33	Q5101048	销轴	Shaft	2	
34	Q40110	平垫圈	Washer	2	
35	Q5003214	开口销	Split pin	2	
36	WG9000360703	储气筒总成Φ275/40L	Air reservoir (40L)	2	
38	WG9719360024	紧固带总成	Tension strap	4	
40	WG09 190017	拉紧销	Tension pin	4	
42	WG700 550013	张紧销	Tension pin	4	
44	Q218B0880	内六角圆柱头螺钉	Screw	4	
45	WG9000361402	放水阀	Draining valve	4	
47	190003179781	聚酰胺管 (Φ8*1)	Plastic pipe (Φ8*1)	22m	
48	190003179785	聚酰胺管 (Φ12*1.5)	Plastic pipe (Φ12*1.5)	30m	
50	AZ9725360102	管子15软管/干燥器1	Tube	1	
51	190003559515	管接头用螺母	Nut	2	
52	190003559562	卡套	Connector	2	
53	AZ9100362002	卡套式直角接头体	Connector	1	
54	WG9000361015	六角薄螺母M22X1.5	Nut M22X1.5	1	
56	WG9000361016	支撑垫圈M22X1.5	Washer M22X1.5	1	

8.17 牵引底盘制动装置/Chassis Brake Device

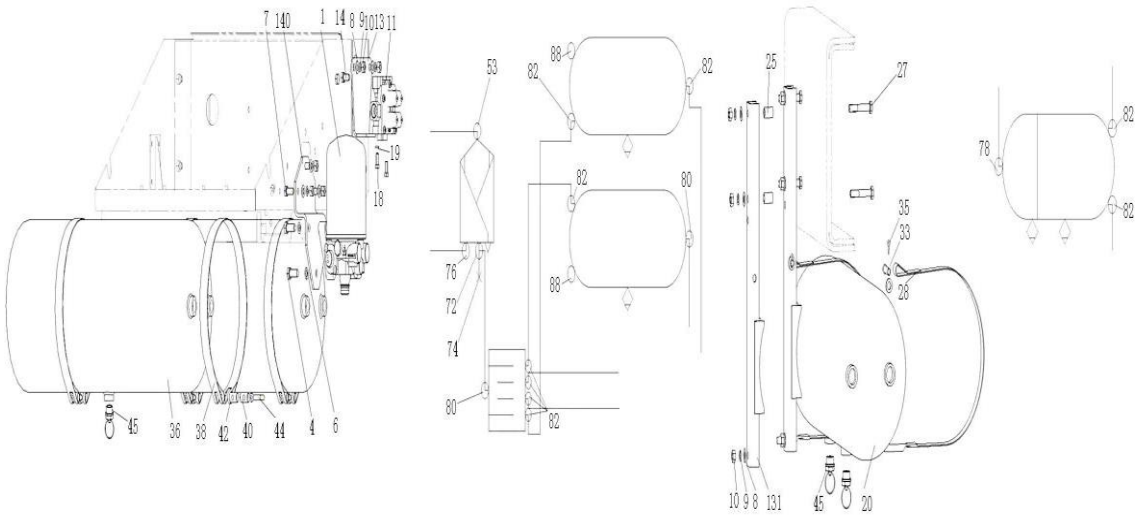

8.17 牵引底盘制动装置/Chassis Brake Device

序号	零部件图号	名称	Part Name	数量	备注
No.	Part No.			Qty	Remark
58	WG9000361017	O型圈20.3X2.4	O-ring 20.3X2.4	1	
60	WG9000361004	弹性元件NG8	Elastic part NG8	1	
62	WG9000361005	卡簧NG8	Snap ring NG8	1	
64	WG9000361006	螺母座NG8	Nut seat NG8	1	
66	WG9000361007	弹性元件NG12	Elastic part NG12	13	
68	WG9000361008	卡簧NG12	Snap ring NG12	13	
70	WG9000361009	螺母座NG12	Nut seat NG12	13	
72	WG9000361301	L型三通接头体NG12/NW1	"L" Connector NG12/NW12	1	
74	WG9000361401	压力测试接头总成	Pressure test connector	1	
76	WG9000361201	直角接头体NG8/NW6	Connector NG8/NW6	1	
78	WG9000361202	直角接头体NG12/NW6	Connector NG12/NW6	2	
80	WG9000361203	直角接头体NG12/NW12	Connector NG12/NW12	2	
82	WG9000361204	直角接头体NG12/NW9	Connector NG12/NW9	10	
84	WG9000361306	T型三通接头体NW9/NG12/NG6	"T" Connector NW9/NG12/NG6	2	
86	WG9000361106	直通接头体NG8/NW6	Connector NG8/NW6	2	
88	WG9000361012	堵塞NG12-M22X1.5	Plug NG12-M22X1.5	1	
90	WG9000361323	L型三通接头体NW6/NW9/NW9	"L" Connector NW6/NW9/NW9	1	
92	AZ9003179031	穿线护套	Protection sleeve	150mm	
93	190003179046	穿线护套	Protection sleeve	150mm	
94	190003179046	穿线护套	Protection sleeve	150mm	

8.17 牵引底盘制动装置/Chassis Brake Device

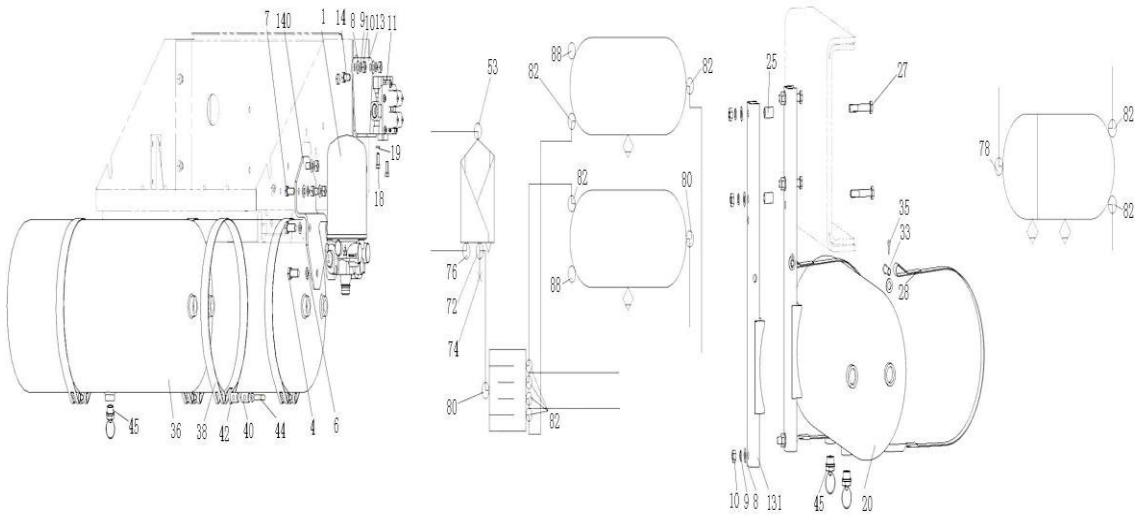

8.17 牵引底盘制动装置/Chassis Brake Device

序号	零部件图号	名称	Part Name	数量	备注
----	-------	----	-----------	----	----

No.	Part No.	名称	Part Name	Qty	Remark
95	WG17017361000	螺旋形护管	Protect pipe	2	
97	WG17017361000	螺旋形护管	Protect pipe	2	
99	WG9123360300	波纹护套 (φ30 黑色)	Protection sleeve	200cm	
101	WG9100360134	隔环	Spacer ring	10	
102	199100360134	隔环	Spacer ring	1	
103	WG9100360135	隔环	Spacer ring	10	
104	199100360135	隔环	Spacer ring	1	
106	190003171392	塑料紧固带	Fastener	25	
107	190003179030	护垫	Protecting cushion	39cm	
108	190003179030	护垫	Protecting cushion	39cm	
109	199012360441	角形支架	Bracket	1	
110	Q150B1035	六角头螺栓	Screw	1	
111	Q40110	平垫圈	Washer	1	
112	Q40310	弹簧垫圈	Spring washer	1	
113	Q340B10	六角螺母	Nut	1	
116	Q150B0620	六角头螺栓	Screw	1	
117	Q40106	平垫圈	Washer	1	
118	Q40306	弹簧垫圈	Spring washer	1	
119	Q340B06	I型六角螺母	Nut	1	
121	Q150B1225	螺栓	Screw	1	

8.17 牵引底盘制动装置/Chassis Brake Device

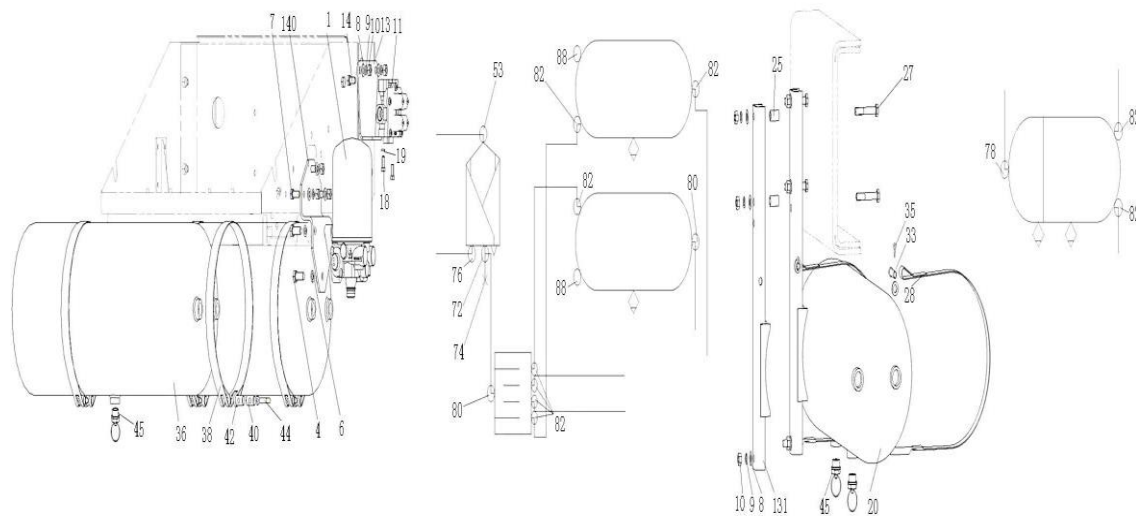

8.17 牵引底盘制动装置/Chassis Brake Device

序号	零部件图号	名称	Part Name	数量	备注
No.	Part No.			Qty	Remark
122	Q40112	平垫圈	Washer	1	
123	Q40312	弹簧垫圈	Spring washer	1	

124	Q340B12	I型六角头螺母	Nut	1	
125	1880 360083	支承板	Plate	1	
126	Q150B1035	六角头螺栓	Screw	1	
127	Q40310	弹簧垫圈	Spring washer	1	
128	Q340B10	六角螺母	Nut	1	
129	Q40110	平垫圈	Washer	1	
131	WG9731360002	储气筒支架总成	Bracket	2	
138	WG9100360165	角形支架	Bracket	1	
140	WG9719360014	空气干燥器支架	Bracket	1	
142	WG9003170002	聚酰胺管(Φ16*2)	Plastic pipe (Φ16*2)	3m	
144	WG9003171390	塑料紧固带B5*180	Fastener B5*180	30	
146	WG85 770036	紧固夹子	Clip	1	
148	WG1000060211	橡胶软管(Φ15/Φ21)	Hose (Φ15/Φ21)	1	
150	WG9725270012	电磁阀支架	Bracket	1	

8.18 半挂牵引车前轴制动装置/Front Axle Brake Device 2

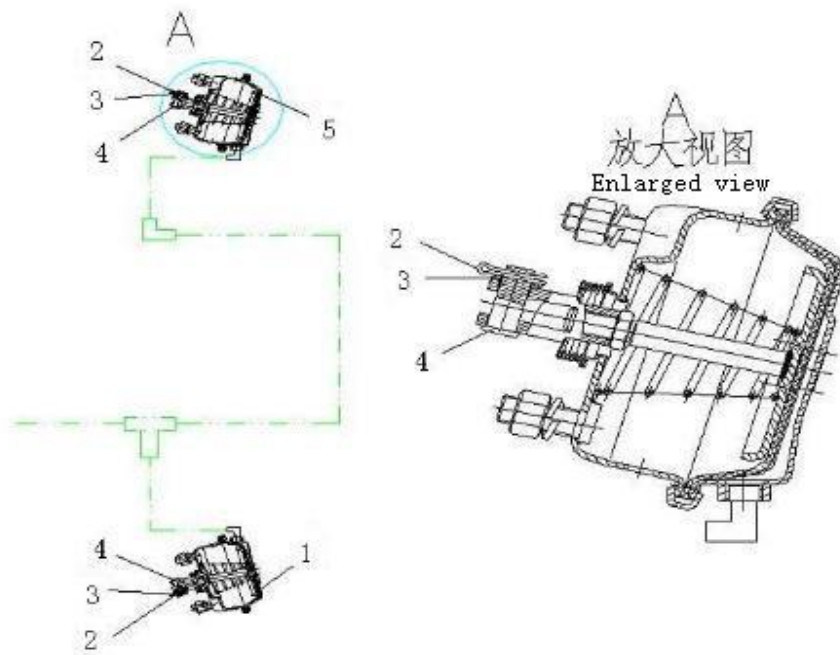

8.18 半挂牵引车前轴制动装置/Front Axle Brake Device 2

序号 No.	零部件图号 Part No.	名称	Part Name	数量 Qty	备注 Remark
1	WG9000360100	24"膜片式制动气室(左)	Spring brake actuator -left	1	
2	Q5004025	开口销	Split pin	2	
3	Q40114	平垫圈	Washer	2	
4	Q5101440	销轴	Shaft	2	
5	WG9000360101	24"膜片式制动气室(右)	Spring brake actuator -right	1	

